



AFINIA LABEL[®]

LABEL APPLICATOR FOR BAGS and POUCHES AP200



User Manual



Content

1. Introduction	page 3
Applicator Operation	page 4
Description	page 5
Scope of delivery	page 5
Technical data	page 5
Noise information	page 6
2. General safety instructions for handling electrical appliances.	
Safe work	page 7
Specific safety instructions	page 7
3. Operating instructions.	
Installation	page 8
Power on	page 8
Setting 'Offset start'	page 8
Setting 'Offset stop'	page 8
Loading labels and calibrating the label sensor	page 9
Positioning of the bag	page 9
Working with the menu and changing parameters	page 9
Verify settings	page 9
Labeling	page 10
Errors	page 10
Service menus	page 10
Adjusting of the display	page 10
4. Offset start	page 11
5. Offset stop - mode 1 label	page 12
6. Offset stop 1, Offset stop 2 - mode 2 labels	page 13
7. Loading labels	page 15
8. Calibrating up the label sensor	page 16
9. Working with the menu and changing parameters	page 17
10. Working with the service menu and changing parameters	page 19
11. Errors and actions.	page 21
12. Adjust the brightness and contrast of the display	page 22
13. Service menu - counters	page 23
14. Service menu - inputs	page 23
15. Maintenance and cleaning	page 24
16. Service	page 24
17. Warranty	
General terms	page 25
Warranty conditions	page 25
18. Transportation	page 25
19. Disposal	page 25
20. Contact Support	page 26



In the present Operation Manual have been used the following pictograms.

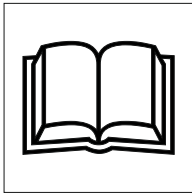

Read the User Manual!



Follow safety warnings and instructions!

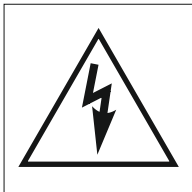

Protect yourself from electric shock. Danger to life!

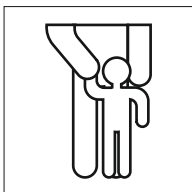

Keep children away from the machine!

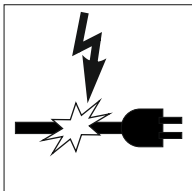

Risk of life from electric shock when a power cord or plug is damaged!

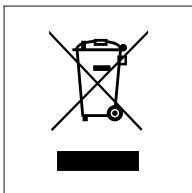

Dispose the packaging and the appliance in accordance with environmental regulations!

1. Introduction

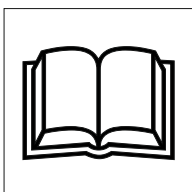

Before using the machine for the first time, it's important to become familiar with its functions and learn about the proper operation of the applicator. To do this, please read the operating instructions provided. It's important to follow the instructions outlined in the manual. If you are handing over the machine to someone else, be sure to include all documentation.



Applicator operation

The machine is specifically designed to apply labels to a bag or pouch. The labels must be on a single roll or arranged in order on the roll for two label applications.

To operate the machine, place the bag or pouch into the guide plate, between the adjustable guides, and the system will automatically start. As the bag moves through the guide, the machine applies the label.

Any other use of the machine is not authorized and poses significant risks of accidents. The manufacturer cannot be held responsible for any faults or damage caused by misuse of the machine.

The machine's electrical protection is achieved through the protective sheath of current-carrying parts and the grounding of the metal housing. It's important to connect directly to a wall outlet. The machine also features built-in fuses for overcurrent protection, which should only be replaced by qualified personnel.

Attention !



It's important to follow the technical specifications and not place bags or pouches in the machine that are larger or smaller than the specified sizes. Do not use damaged bags or pouches.

Only use labels that are within the specified size range and only maintain and clean the machine when the power is off.

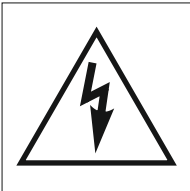

Do not cover the ventilation openings of the machine and be careful not to spill liquid on it. Do not insert objects into the openings of the machine, as this poses a risk of electric shock.

Do not place your hand or fingers on the shafts of the machine! There is a risk of injury!



Attention !

In case of electric shock, immediately disconnect the power cord from the applicator.

Get medical attention immediately.



Description (Figure 1.1, Figure 1.2)

1. Media support plate
2. Pull shaft for the bag
3. Peeling edge
4. Pull shaft for the labels
5. Pressing shaft for the labels
6. Levers for locking / unlocking the pressing shaft
7. Media path assembly
8. Label roll
9. Label roll guides
10. Label roll holder
11. Bag adjustable guides
12. Display control panel
13. Push Button
14. Connector for external device
15. Power connector
16. Power on / off switch
17. Label roll core holder
18. Label gap sensor
19. Guide shaft
20. Label roll guides

Included Items:

- 1 AP200 label applicator
- 1 power cable 110V or 220V
- 1 User manual

Technical data.

Supply voltage:	110V, 60Hz or 220V, 50Hz
Power consumption:	< 1A
Electrical connection:	Power cord
Dimensions:	440mmW, 230mmH, 330mmD(17.32"x9"x13")
Machine weight:	15kg. (33 lbs.)
Width of the bag:	80 to 250mm (3.15" to 9.84")
Length of the bag:	120 ... 350mm (4.72" to 13.78")
Thickness of the bag/pouch:	< 5mm (.2")
Diameter of the labels roll:	< 200mm (7.87")
Core diameter:	46 to 76mm (1.8" to 3")
Width of the roll / label:	25 ... 230mm (1" to 9")
Label length:	25 ... 300mm (1" to 11.8")
Gap between labels:	> 2.5mm (.11")
Application Speed:	0.03 to 0.1m/sec.
Distance from the top of the bag to the start of the label:	> 40mm (1.58")

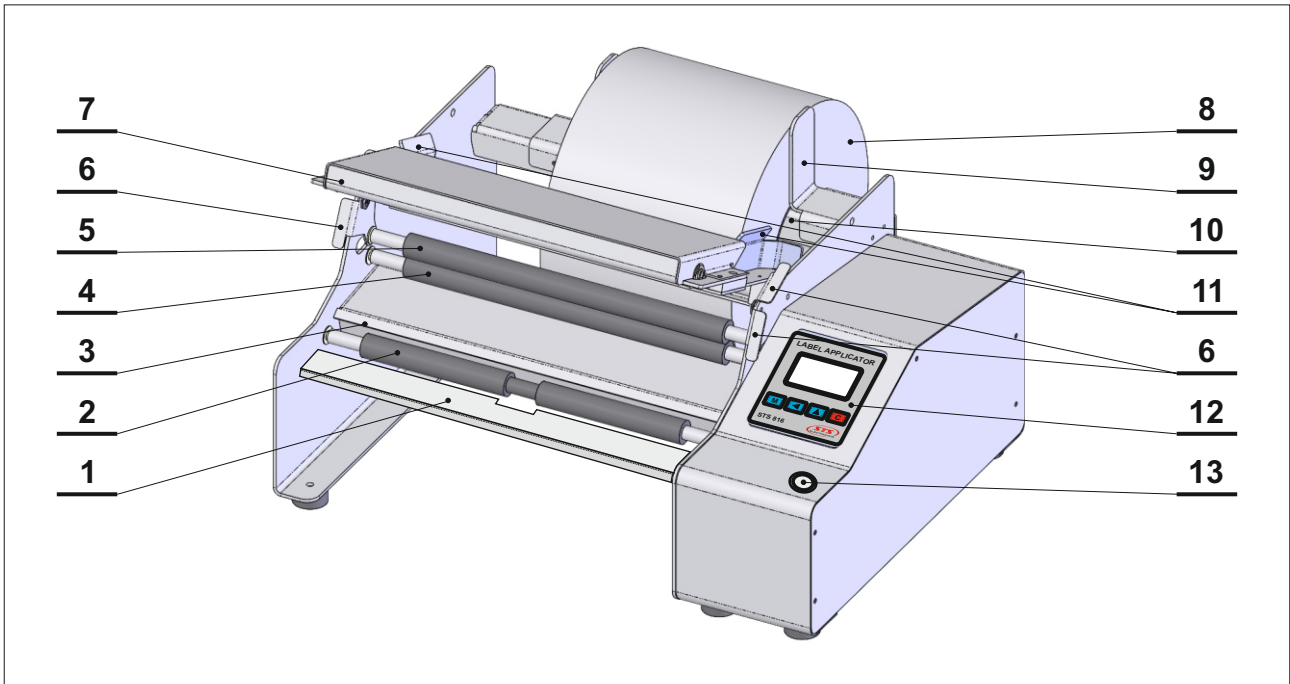

fig. 1.1

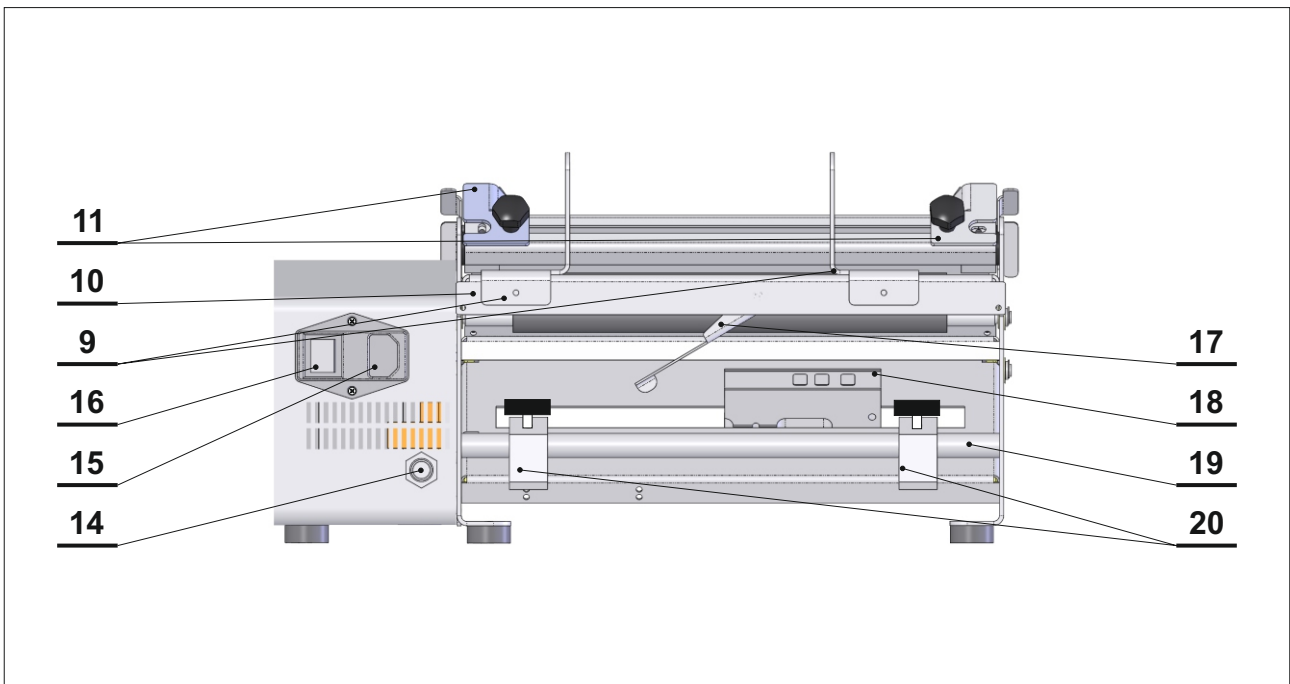

fig. 1.2

Noise information.
Noise level <75dB.



2. General safety instructions for handling electrical appliances.



Attention!

The following safety precautions must be observed when using electrical appliances to protect against electric shock, risk of injury and fire. Read all of these instructions before using the machine.

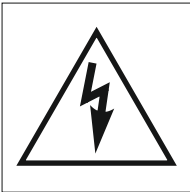

-Keep the workplace in clean. Clutter in the work area can lead to accidents.
-Ensure good lighting in the workplace.

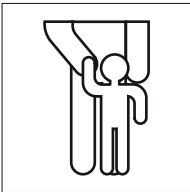

-Do not use the applicator in humid conditions.
-Do not use the applicator in places where there is a risk of fire or explosion.
-Keep children away from the applicator when operating the device.
-Do not use the applicator for purposes other than those intended.
-Do not use the cord to pull the plug from the wall socket. Protect the cable from excessive heat and sharp edges.

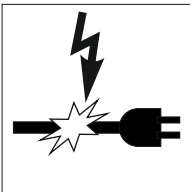

-Carefully maintain your applicator.
-If you do not use the applicator, remove the power cord from the socket.
-Do not use the applicator with a damaged power cord or power switch.

Before using the applicator, check for any damage. Ensure that all moving parts are functioning properly and aren't too tight or loose. Ensure that there are no damaged parts. All components must be installed correctly and meet the necessary conditions to ensure that the applicator will working correctly. Any damaged safety components or parts should be repaired by a certified technician or replaced, as specified in the user manual. Circuit breakers that are damaged must be replaced by a certified technician.

Specific safety instructions.

The bags are inserted manually. The labeling procedure is started automatically when the bags enters the machine.

- Do not insert a new bag while the previous bag is being labeled.
- Do not insert more than one bag at a time.
- Do not lift the media path while a bag is being labeled.
- Do not forcibly remove a bag.

Failure to follow these instructions may result in injuries or damages.



3. Operating instructions



Attention !

Operators working with this machine (AP200) should be familiar with the user manual.

Installation:

The machine should be placed on a flat, horizontal surface larger than its base. Provide space around the machine for maintenance, servicing and handling. Only use the power cord supplied with the unit.

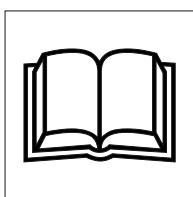

Turn ON.

After turning on the power, the welcome logo appears on the display, followed by the machine information (Fig. 3.1) and then switches to operating mode (Fig. 3.2).

Determination of "Offset start" and length of the bag

The "Offset start" parameter determines the positioning of the label on the bag. This value is in MM. The minimum distance from when the bag is detected to when the label is applied is 40mm. The offset start value is added to the 40mm value.

For two labels, two parameters are entered - "Offset start 1" for the first label and "Offset start 2" for the second label.

Measure the length of the bag and enter in that value. The supported sizes for bags are listed above.

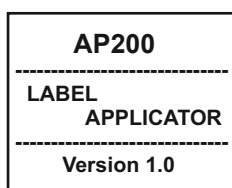

fig. 3.1

Determination of "Offset stop".

The sensor reading the end of the label is 100 mm behind the peeling edge and its position cannot be changed. This requires entering an offset stop parameter. Offset stop 1 and Offset stop 2 are required for two labels.

This parameter determines the correct positioning of the next label to the peel-off edge. The values depend on the length of the label and the gap.

The one label mode is described in Chapter 5. Offset stop - mode 1 label. The two label mode is described in Chapter 6. Offset stop 1, Offset stop 2 - mode 2 labels.

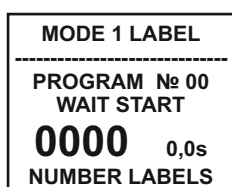

fig. 3.2

The online tool to calculate the values can be found on our website, <https://afinialabel.com/calculate-ap200>. This QR code will take you to the webpage.





Loading labels and setting up the label sensor.

The machine is loaded with a label roll meeting the requirements described in the specifications section. For better access, the media path assembly can be raised. The procedure is performed with the power off. Refer to Chapter 7 - Loading labels.

The gap sensor is calibrated with the power on.
Refer to: Chapter 8. Setting up the label sensor.

Positioning of the bag

Position the bag in relation to the label stock. The guides should be adjusted to allow the bag to pass freely through the media path.

Working with the menu and changing parameters

The applicator has two menu types: user menu and service menu.

The user menu is for the machine operator and allows for adjustments to language, operating mode (single or double label), start offset, stop offset and bag length. Refer to Chapter 9 for more details.

The service menu is reserved for service support and allows for enabling/disabling the user menu password, adjusting speed, and enabling/disabling fast platform speed. Refer to Chapter 10 for details.

Verifying settings

- Monitor the position of the label, confirming it is flush with the peeling edge. If it is not, this can be corrected by changing the Offset Stop value
- Monitor the left / right position of the label. Use the side guides to adjust the position.
- Monitor the start position of the label. This can be changed by modifying the Offset Start value.



Labeling

The labeling procedure is done by placing a bag in the media path assembly. The display shows executing. When labeling is completed, the machine stops and the label counter increases. Any time you press and hold the button  for more than 3 seconds, the counter resets.

Errors.

If an error occurs during machine startup or operation, the applicator will stop. An error message will show on the display and the system will beep. To fix the problem, the error needs to be resolved. To clear the error, press and hold the button located under the control panel (for more than 3 seconds) or restart the machine by switching the power off and on. Error codes, possible causes and their solutions are described in Chapter 11: Errors and Actions.

Once the problem has been resolved, the machine will resume working correctly. However, if a problem occurs during startup, an error message will be on the display after the power on sequence is completed.

Adjusting the display.

The brightness and contrast of the display can be changed as needed. Details are described in Chapter 12. Adjust the brightness and contrast of the display

Service menus.

There are two service menus.

First is the counter menu. It lists the event counters, total counter and error counter as well as the machine serial number. The description of the counters and the access to them are described in: Chapter 13. Service menu - counters

The second menu allows for diagnostics of all the sensors. Details are described in:

Chapter 14. Service menu - inputs.

Attention



After labeling is complete, unplug the machine.

In order to prevent damage to the rubber shafts, raise the media path assembly and unlock the pressure shaft, when the system is not being used.



4. Offset start.

Determining Offset Start parameter

This value determines the position of the label on the bag. It is set in millimeters. The minimum distance for the top of the bag to the start of the label is ~ 40mm. The sum of the minimum distance and the offset start parameter determine the beginning of label. Figure 4.1.

When applying both a front and rear label, it is necessary to enter two parameters "Offset start 1" and "Offset start 2" - respectively for the positioning of the first label and second label.

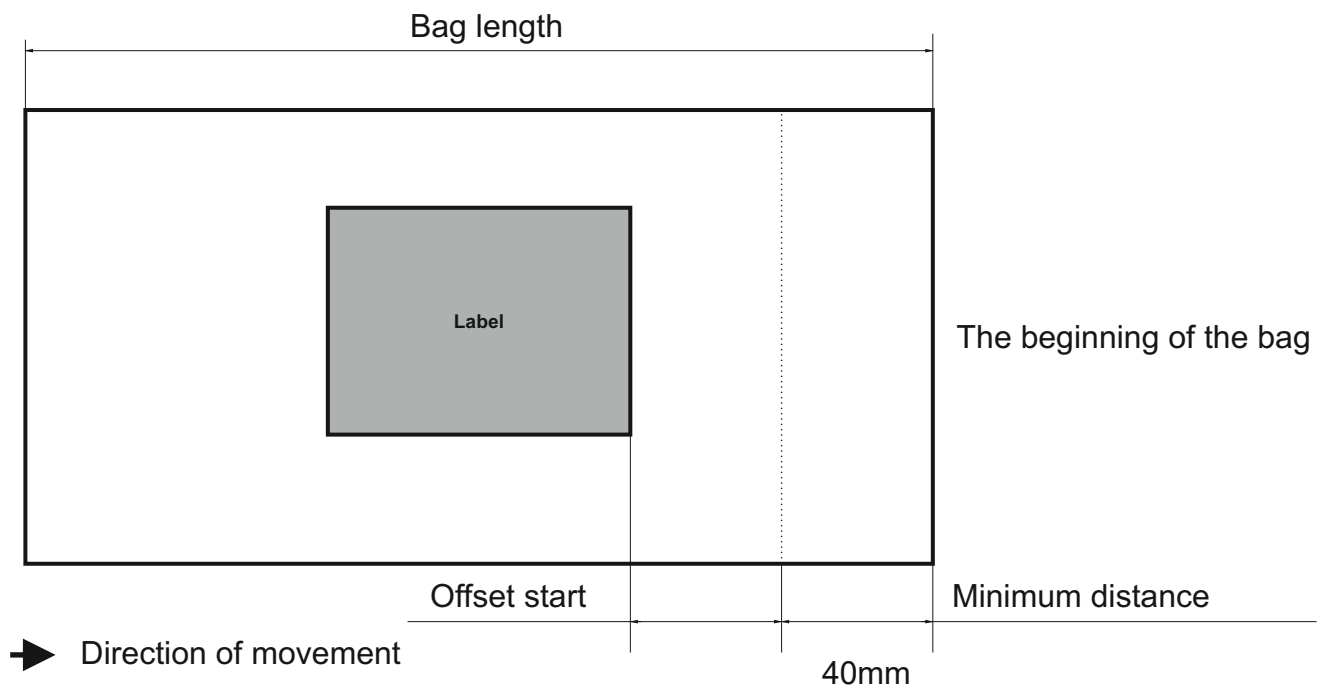

Figure 4.1

The online tool to calculate the values can be found on our website, <https://afinialabel.com/calculate-ap200>. This QR code will take you to the webpage.





5. Offset stop - 1 label mode

Determination of 'Offset stop'

The online tool to calculate the values can be found on our website, <https://afinialabel.com/calculate-ap200>. This QR code will take you to the webpage.



Determines the correct position of the next label.

There are 3 possible scenarios and they are shown on Figure 5.1

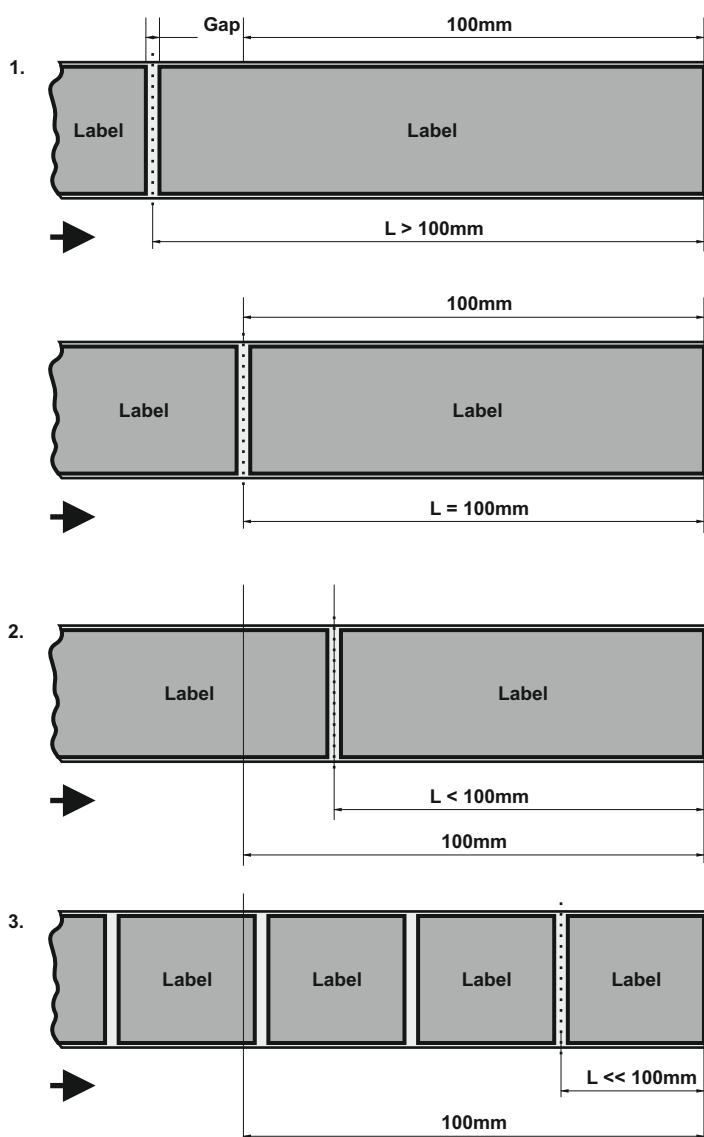

Figure 5.1

Scenario 1:

Label > 100 mm.
Offset value is 100:
Offset stop = 100.

Scenario 2:

Label < 100mm.
The length of the label used is less than L. The Offset value shall be determined by subtracting the length of the label and the half of the gap from 100 [mm].
Offset stop = 100 - (Label + Gap/2).

Scenario 3:

Label << 100mm.
The length of the label used is several times less than L. The Offset value is determined by subtracting from 100 [mm] the sum of all lengths of the fitted labels and gaps between them, and adding the half of the gap.

For the specific example:

Offset stop = 100 - (Label + Gap + Label + Gap + Label + Gap + Gap/2).

Condition:

If the sum of label(label) + gap = 100 mm or = 100..200..300..etc.

Offset stop is 1.

Note: Minor adjustments may be needed to get the desired label position.



6. Offset stop 1, Offset stop 2 - mode 2 labels.

Determination of 'Offset stop1', 'Offset stop2'

Determination of Offset stop1 and Offset stop 2 to the right positioning of the beginning end of the following (subsequent label) to the peeling edge.

There are some possible variants:

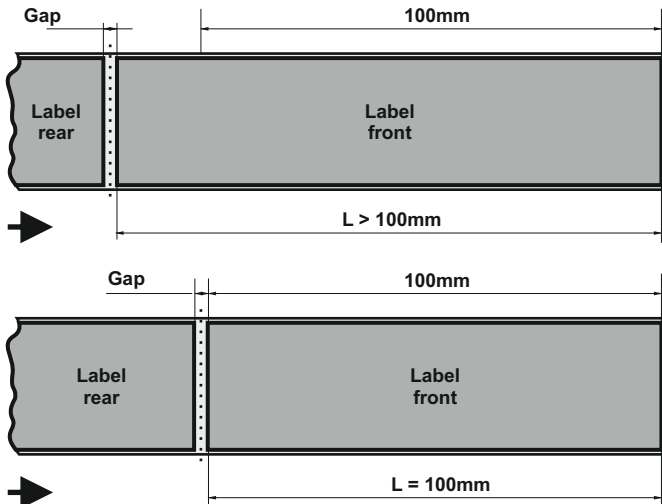

Figure 6.1

Scenario 1:

Front label > 100mm

Rear label - any size

-Figure 6.1.

The value of Offset stop 2 is determined by adding the length of half of the gap to the length of the rear label:

Offset stop 2 = Rear label + Gap/2.

To determine the value of Offset stop 2, add half of the gap length to the length of the rear label: **Offset stop 2 = Rear label + Gap/2.**

The machine must start with the front label.

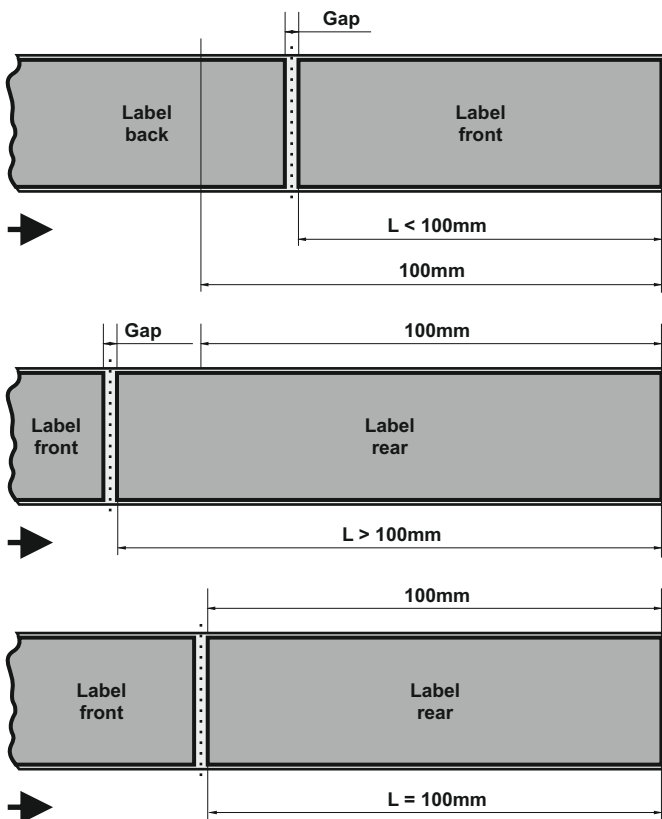

Figure 6.2

Scenario 2:

Front label < 100mm

Rear label > 100mm -

Figure 6.2.

The value of Offset stop 1 is determined by adding the length of half of the gap to 100:

Offset stop 1 = 100 + Gap/2.

The value of Offset stop 2 is determined by adding the length of half of the gap to the length of the Front label:

Offset stop 2 = Front label + Gap/2.

The machine must start with a rear label in this scenario.

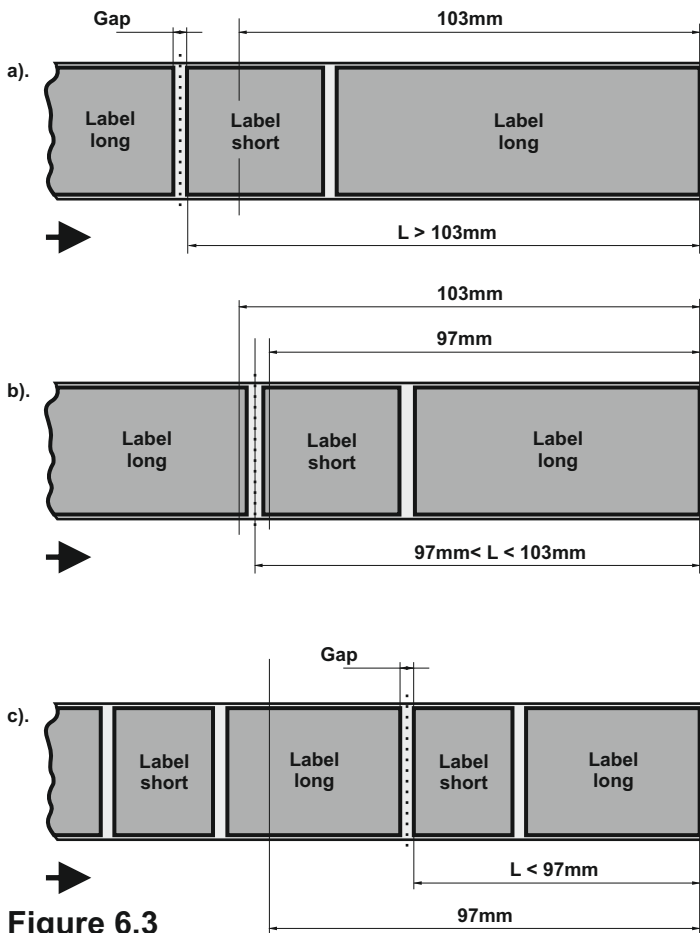

Figure 6.3

Scenario 3:

Front label < 100mm
 Rear label < 100mm - Figure 6.3.
 There are three options:

a). - the sum of the lengths of the two labels and the gap is greater than or equal to 103mm. The value of Offset Stop 1 is then determined by subtracting the length of the shorter label and the length of half of the gap from 100:
Offset stop 1 = 100 - (Short label + Gap/2).

The value of Offset Stop 2 is determined by adding the length of half of the gap to the length of the Short Label:

Offset stop 2 = Short label + Gap/2.

The machine must start with a long label.

b). - the sum of the lengths of the two labels and the gap is less than 103mm but greater than 97mm.

Then the value of Offset stop 1 is equal to the length of half the gap:

Offset stop 1 = Gap/2.

The value of Offset Stop 2 is determined by adding the length of half of the gap to the length of the Short Label:

Offset stop 2 = Short label + Gap/2.

The machine must start with a long label.

c). - the sum of the lengths of the two labels and the gap is less than or equal to 97mm. Then the value of Offset stop 1 is determined by subtracting from 97 the length of the two labels with the gap between them and the length of another half gap: **Offset stop 1 = 97 - (Long label + Gap + Short label + Gap/2).**

The value of Offset Stop 2 is determined by adding the length of half the gap to the length of the Short Label:

Offset stop 2 = Short label + Gap/2.

The machine must start with a long label.

Note: Minor adjustments may be needed to get the desired label position.



7. Loading labels.

Label rolls are loaded according to the **Label Path Diagram** - Figure 7.1.

The **Label roll** is placed on **Stand for label roller**. **Pressing shaft** is unlocked by lifting the levers on both sides. It is best to remove labels from the roll and then follow the diagram below for loading the label stock.

- the **Media Path assembly** is raised;
- go under the Guide Shaft, between the Guides;
- goes through the slot in the **Label sensor**;
- goes around the **Peeling edge**;
- passes over the **Pulling Shaft** and under the **Pressing Shaft**;
- passes over **Label roll**
- **Media Path assembly** is lowered.

The **label roll** is positioned so that it passes through **Label sensor** in far enough to properly engage the sensor. For sensor calibration, refer to chapter 8. **Setting up the label sensor**. The beginning of the label is positioned next to the **Peeling Edge**. **Pressing shaft** is moved to the lock position. **Roll guides** are moved up against the label roll, leaving a small amount of space. If the guides are too tight, the label roll will not turn. The guides located before the sensor are moved into position. Do not press these up against the label stock.

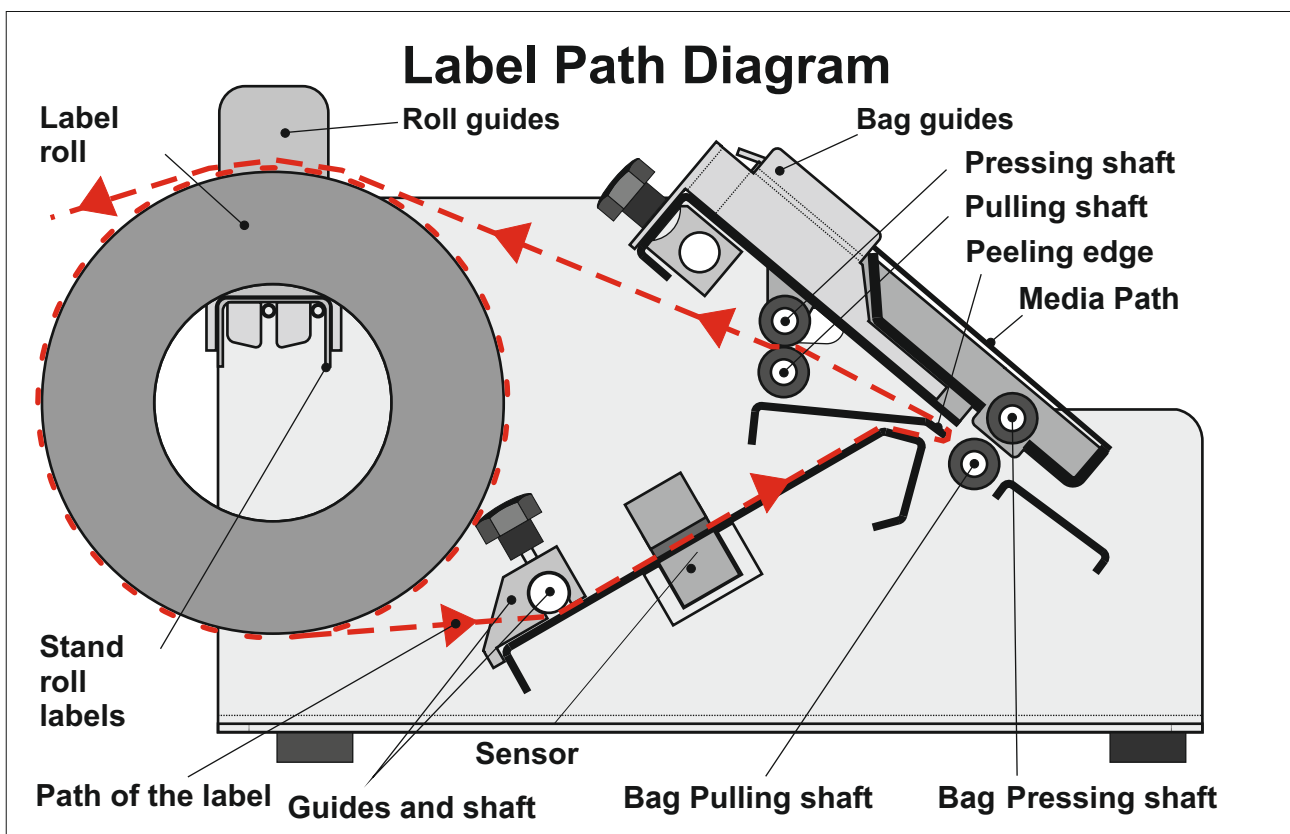

Figure 7.1

V.2.01



8. Setting up the label sensor

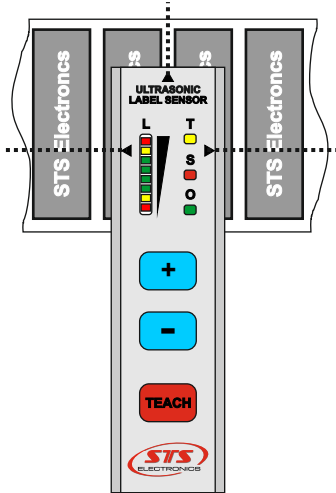

Fig. 8.1

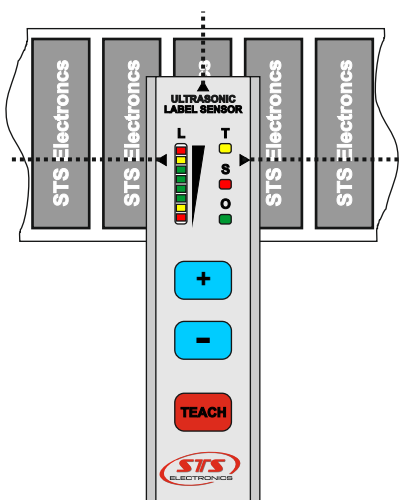

Fig. 8.2

The label stock must travel far enough inside the sensor, going past the side arrow markings. The sensor and the label stock **must be** at rest during calibration!

1. Position the label stock on a gap. Figure 8.1.

2. Press and hold **TEACH** button for more than 3 seconds - The yellow 'T' LED turns on. The sensor is in calibration mode. When the button is released, the LED starts blinking and the sensor training begins. The signal level indicated by the bargraph 'L' will increase. Wait for 'T' LED to go out.

3. Position the label stock on a label - Fig.8.2.

4. The **TEACH** button is pressed. 'T' LED lights up. When the button is released, the LED starts to blink. When the 'T' LED turns off, calibration is complete.

If the gap signal level is insufficient after step 2 or there is not enough difference between the gap and label levels, the bargraph starts to blink - indicating an error. The media is not compatible with this applicator.



9. Working with the user menu and changing parameters.

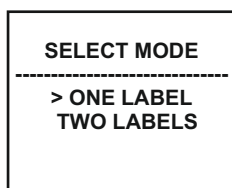

Select 'ONE LABEL' mode.

To change modes, press and hold the **M** button for 3 seconds. Use the **^** button to select the ONE LABEL mode. (Figure 9.7). Press the **M** button. The OFFSET START screen appears. (Figure 9.8). Refer to chapter 4 to determine the offset start value.

Figure 9.7

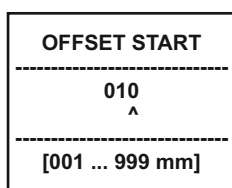

To enter the value, press the **^** button. Once the value is set, press the **<** button, to move to the next location. Press the **^** button until the value is selected.

Once the three numbers are shown, press the **M** button.

Figure 9.8

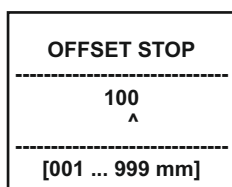

The next value, OFFSET STOP, is shown (Figure 9.9).

To determine the OFFSET STOP value, refer to chapter 5.

Enter the OFFSET STOP value by pressing the **^** button. Once the number is correct, press the **<** button, to move to the next digit. Use the **^** button to set the value.

Figure 9.9

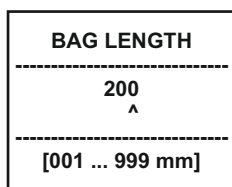

Once the numbers are entered, press the **M** button.

The next screen to appear will be the BAG LENGTH value (Figure 9.10).

Enter the BAG LENGTH value by pressing the **^** button. Once the number is correct, press the **<** button, to move to the next digit. Use the **^** button to set the value.

Figure 9.10

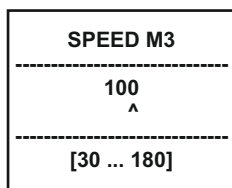

Once the numbers are entered, press the **M** button. The UI will return to the main screen (Figure 9.7).

Figure 9.11

Select mode 'TWO LABELS'.

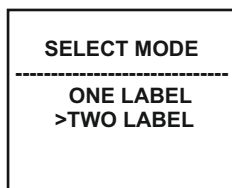

To change modes, press and hold the **M** button for 3 seconds. Use the **^** button to select the TWO LABEL mode (Figure 9.12). Press the **M** button. The next screen will be OFFSET START 1 (Figure 9.13). Refer to chapter 4 to determine this value.

Figure 9.12

Enter the OFFSET START 1 value by pressing the **^** button. Once the number is correct, press the **<** button, to move to the next digit. Use the **^** button to set the value.

Once the numbers are entered, press the **M** button.



OFFSET START 1
010 ^
[001 ... 999 mm]

Figure 9.13

The next screen is OFFSET START 2 (Figure 9.14). Refer to chapter 4 to determine this value.

Enter the OFFSET START 2 value by pressing the **^** button. Once the number is correct, press the **<** button, to move to the next digit. Use the **^** button to set the value.

OFFSET START 2
010 ^
[001 ... 999 mm]

Figure 9.14

Once the numbers are entered, press the **M** button.

The next screen is OFFSET STOP 1 (Figure 9.15). Refer to chapter 6 to determine this value.

OFFSET STOP 1
100 ^
[001 ... 999 mm]

Figure 9.15

Enter the OFFSET STOP 1 value by pressing the **^** button. Once the number is correct, press the **<** button, to move to the next digit. Use the **^** button to set the value.

Once the numbers are entered, press the **M** button.

OFFSET STOP 2
100 ^
[001 ... 999 mm]

Figure 9.16

The next screen is OFFSET STOP 2 (Figure 9.16). Refer to chapter 6 to determine this value.

Enter the OFFSET STOP 2 value by pressing the **^** button. Once the number is correct, press the **<** button, to move to the next digit. Use the **^** button to set the value.

BAG LENGTH
200 ^
[001 ... 999 mm]

Figure 9.17

Once the numbers are entered, press the **M** button.

The next screen to appear will be the BAG LENGTH value (Figure 9.17).

Enter the BAG LENGTH value by pressing the **^** button. Once the number is correct, press the **<** button, to move to the next digit. Use the **^** button to set the value.

Once the numbers are entered, press the **M** button. The UI will return to the main screen (Figure 9.7).



Attention !

When staying in a parameter menu window for more than 60 seconds without activity (pressing any key), the machine enters Figure 9.7 operating mode. Changes made will be saved.



10. Working with the service menu and setting parameters.

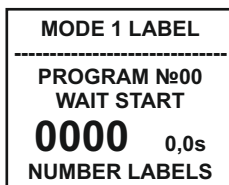

Figure 10.1

Access to the parameter change menu is password protected. When you are on the main screen (Figure 10.1), press and hold the **C** and **M** buttons at the same time, for 3 seconds. The password screen appears (Figure 10.2). The password is 8888.

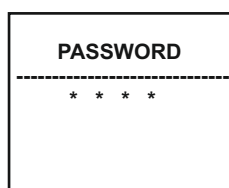

Figure 10.2

Use the **^** button to scroll through the numbers. Once 8 is displayed, press the **<** button to move to the next location (Figure 10.3). Use the **^** button until 8 is displayed. Use the **<** button to move to the next location. Repeat this until all four numbers are entered. Press the **M** button to go to the next screen (Figure 10.5).

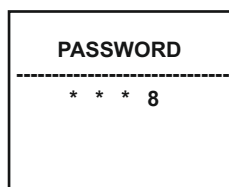

Figure 10.3

If the password is entered incorrectly, an error message will appear (Figure 10.4).

Use the **^** button to set the password on (Figure 10.5) or set the password to off (Figure 10.6).

Press the **M** button to save the setting.

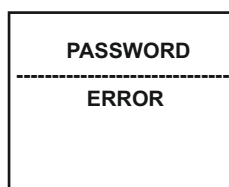

Figure 10.4

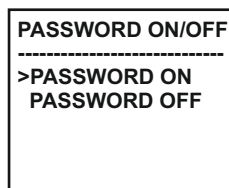

Figure 10.5

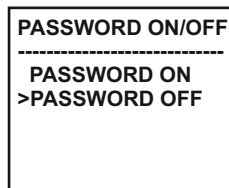

Figure 10.6

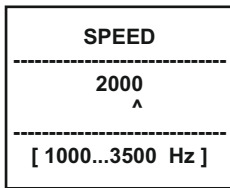

Figure 10.7

NOTE: The speed of the motor can be changed but should only be done when instructed by a support technician. Use the **^** button to change the value. Press the **<** button to move to the next digit. The value must be between 1000 and 3500 Hz (Figure 10.7).

Once the value is set, press the **M** button. The display will return to the main screen (Figure 10.1).



Attention !

When staying in a parameter menu window for more than 60 seconds without activity (pressing any key), the machine returns to the operating mode screen (Figure 10.1). Any changes made will be saved.

Note:

Heavy and large bags may require lower speeds.



11. Errors and events.

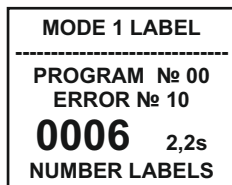

Figure 11.1

ERROR 10 (Figure 11.1) The rotation of the shaft that moves the bag stops.

Possible causes:

- Incorrectly entered value for the length of the bag. Measure and enter a correct value.
- Optical sensor 2 does not respond to the bag - unsuitable bag material for the machine
- Damaged optical sensor 2 or electronic issue. Contact support.

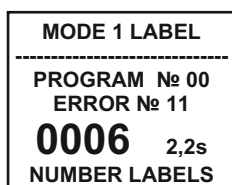

Figure 11.2

ERROR 11 (Figure 11.2)

The rotation of both shafts stops the bag and no label has been applied.

Possible causes:

- Incorrectly entered value for the length of the bag. Measure and enter a correct value.
- The label is longer than the bag. Replace with the correct label.
- Label sensor not calibrated correctly. Recalibration sensor.
- Damaged label sensor or electronic failure. Contact support.

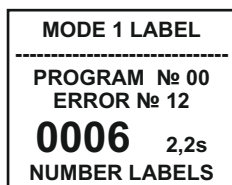

Figure 11.3

ERROR 12 (Figure 11.3)

The bag comes out, there is no signal from the label sensor.

Possible causes:

- Unlocked the pull shaft and lock again.
- No labels. Check the roll for labels.
- Label sensor is not calibrated correctly. Recalibrate sensor.
- Damaged label sensor or electronic failure. Contact support.



12. Adjusting the brightness and the contrast of the display.

The menu for changing the display settings is accessed from the operating mode - Figure 12.1.

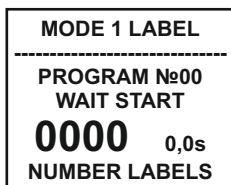

Figure 12.1

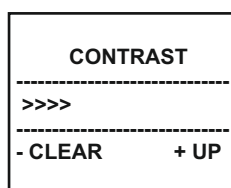

Figure 12.2

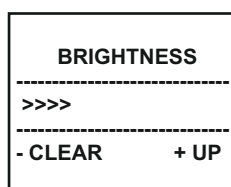

Figure 12.3

Press and hold the **^** button for 3 seconds. the Contrast screen appears (Fig 12.2). Press the **C** button to lower the contrast. Press the **^** button to increase the contrast. Press the **M** button to save the change.

The Brightness screen will appear (Fig 12.3). Press the **C** button to decrease the brightness. Press the **^** button to increase brightness. Press the **M** button to save the change.

The screen will return to the main menu (Fig 12.1).



13. Information service menu - counters.

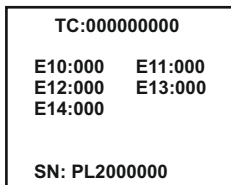

Figure 13.1

The menu provides information about number of machine cycles, number and type of errors as well as last error (Figure 13.1):

- TC:000000000 - total counter of the machine;
- Exx:000 - error number, number of times;
- SN:PL2000000 - serial number.

The menu can be accessed after the power is turned off. Press and hold the button **M**. The power is turned on. After the display lights up and the alarm sounds, the button is released.

Pressing the button **M** again will exit this menu.

14. Information service menu - inputs.

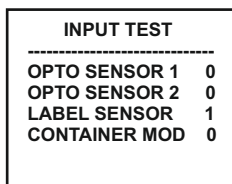

Figure 14.1

Allows testing of the sensors and the inputs of the controller (Figure 14.1):

- OPTO SENSOR 1 0** - optical sensor "START" - in the middle of the media path assembly;
- OPTO SENSOR 2 0** - optical sensor "STOP" - next to the rubber shaft in the media path assembly;
- LABEL SENSOR 1** - sensor gap between labels.

The menu can be accessed after the power is turned off. Press and hold the button **C**. The power is turned on. After the display lights up and the alarm sounds, the button is released.

Pressing the button **M** again will exit this menu.

- 1** - active sensor.
- 0** - inactive sensor.



15. Maintenance and cleaning



Attention! Risk of injury!

Always disconnect the plug from the socket before performing any work on the machine.

The labeling machine does not require any technical maintenance within the specified service life.

Clean the exterior surfaces as needed.

Use a brush or a dry cloth. Do not use solvents to clean the external surfaces or front panel.

Water and lint free cloths may be used to clean the shafts. For adhesive build up, adhesive removal solutions can be used.

Make sure that the vents are always clear.

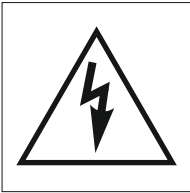

In the event of electric shock or injury, disconnect the power supply immediately by pulling the power cord from the socket!

Get medical attention immediately

16. Service



Attention!

Have the machine serviced by qualified personnel only and only use original spare parts. This guarantees the safety of the machine.

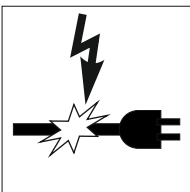

If the power cord is damaged, replace it with a new one. This ensures the protection against electric shock and guarantees the safety of the machine.



17. Warranty

General conditions

The applicator is manufactured with care and has been tested thoroughly. It is designed for use in typical climatic conditions and in an environment with normal safety regulations. Please do not expose it to liquids or gases that may harm the external surfaces. In the event of a warranty claim, please contact technical support.

Warranty conditions

Warranty period: 12 months from the date of sale.

For complete warranty details, please visit our website:
<https://afinialabel.com/product-registration/>

After the warranty period, repairs are paid.

18. Transportation



Attention!

Transport the machine using the original packaging.

Avoid tilting or tipping the machine. Keep away from moisture.

The weight of the machine, with packaging, is 17 kg.

19. Disposal of the machine

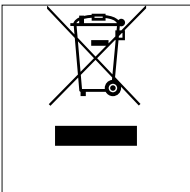

The packaging is made from environmentally friendly materials that you can hand over for recycling.

Do not dispose of electrical appliances with household waste!

According to European Union Directive 2002/96 / EU, end-of-life electrical appliances must be collected separately and disposed of for recycling in accordance with environmental protection requirements.



20. Contact Support

USA:

PH: 952-556-1608

Email: support@afinialabel.com

Afinia Label
8150 Mallory Court
Chanhassen, MN 55317

United Kingdom:

PH: 44-845-250-7949

Email: support@afinia.co.uk

Afinia Label
7 Harriott Drive
Heathcote Industrial Estate
Warwick CV34 6TJ
United Kingdom

FCC Statement

NOTE: This equipment has been tested and found to comply with the limits for a Class A digital device, pursuant to Part 15 of the FCC Rules. These limits are designed to provide reasonable protection against harmful interference when the equipment is operated in a commercial environment. This equipment generates, uses, and can radiate radio frequency energy and, if not installed and used in accordance with the instruction manual, may cause harmful interference to radio communications. Operation of this equipment in a residential area is likely to cause harmful interference in which case the user will be required to correct the interference at their own expense.

CE Conformity

DIRECTIVE 2006/42 / EC, introduced by the Ordinance on Essential Requirements and Conformity Assessment of Machines

DIRECTIVE 2014/30 / EC, introduced by the Ordinance on Essential Requirements and Conformity Assessment for Electromagnetic Compatibility.

The product meets the requirements of the following harmonized standards:

BDS EN ISO 12100: 2011

Machine safety. General principles for design. Risk assessment and reduction risk (ISO 12100: 2010)

BDS EN 60204 - 1: 2006 + A1: 2009

Safety of machinery. Electrical equipment of machines. Part 1: General requirement.

BDS EN 61000-6-2: 2006

Electromagnetic compatibility (EMC). Part 6-2: Common standards. Resistance to interference with industrial environments.

BDS EN 61000-6-4: 2007 +A1: 2011

Electromagnetic compatibility (EMC). Part 6-4: Common standards. Radiation standard for industrial environments.